

# Decentralized Supply for Commerce and Industry – Implementation in Island Regions

Yvonne Eboumbou Ebongue, M. Sc.



1. Introduction
2. Self-consumption and energy communities
3. Technological requirements and challenges
4. Economic Relevance
5. Experience report from Germany
6. Opportunities and prospects for Cape Verde



# A brief Personal Introduction



## **M. Sc. Yvonne Eboumbou Ebongue**

Research associate at Fraunhofer IPA and University of Stuttgart,  
Germany

### Expertise:

- Decarbonization technologies
- Energy efficiency and flexibility
- Photovoltaics and Energy storage systems

# University of Stuttgart & Fraunhofer IPA

## A hub for industrial energy efficiency



### Industrial microgrids and energy storage

- Efficient, flexible and secure electrical supply powered by renewable sources

### Energy policy, strategy & finance

- Survey of current developments and trends in industrial energy efficiency in Germany

### Industrial heating and cooling supply

- Ensuring efficient and sustainable supply of thermal energy for industrial processes

### Energy data analysis

- Data-based optimization of energy systems to increase energy efficiency and flexibility



# Current situation in Cape Verde: Energy Balance & Energy Mix in Cape Verde



- Despite good production, the focus is still heavily on fossil fuels → great potential for expanding renewable energies.
- Relatively low per capita consumption compared to EU values, but island structure brings with it special costs and challenges
- Important goal: Increase the share of renewable energies, integrate storage and control solutions to reduce fossil fuel contributions.

## Energy Mix in 2022

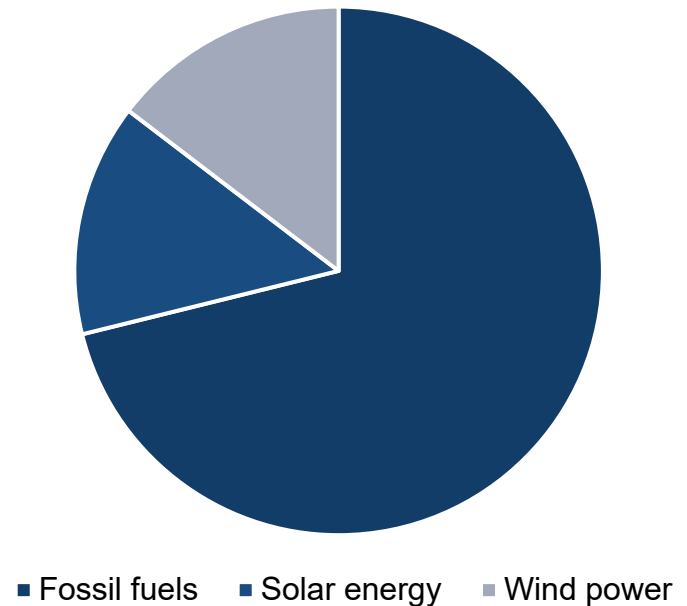

1. Introduction
2. Self-consumption and energy communities
3. Technological requirements and challenges
4. Economic Relevance
5. Experience report from Germany
6. Opportunities and prospects for Cape Verde



# Definition of a Mini-Grid



- A mini-grid consists of several small power generators.
- It may also include energy storage systems.
- It is connected to a local distribution network.
- It supplies a limited group of consumers (e.g., village, industrial park, island grid).
- It is operated independently of the national transmission grid.

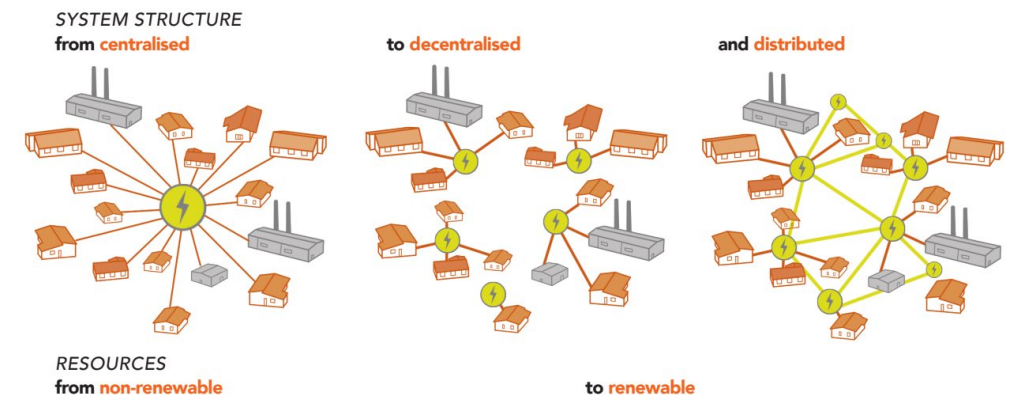
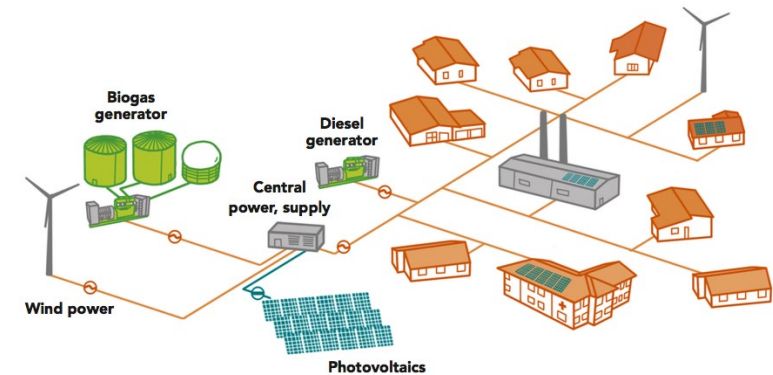

# Mini-Grid: Structure and Scope of Application



Power generation in a mini-grid is mainly achieved using renewable energies, as conventional generators often have too high a generation capacity. However, diesel generators or CHP units are also conceivable, among other things.

Areas where mini-grids are used:

- Remote locations (islands or small villages in developing countries)
- Households
- Critical infrastructure (e.g., hospitals)
- Industry

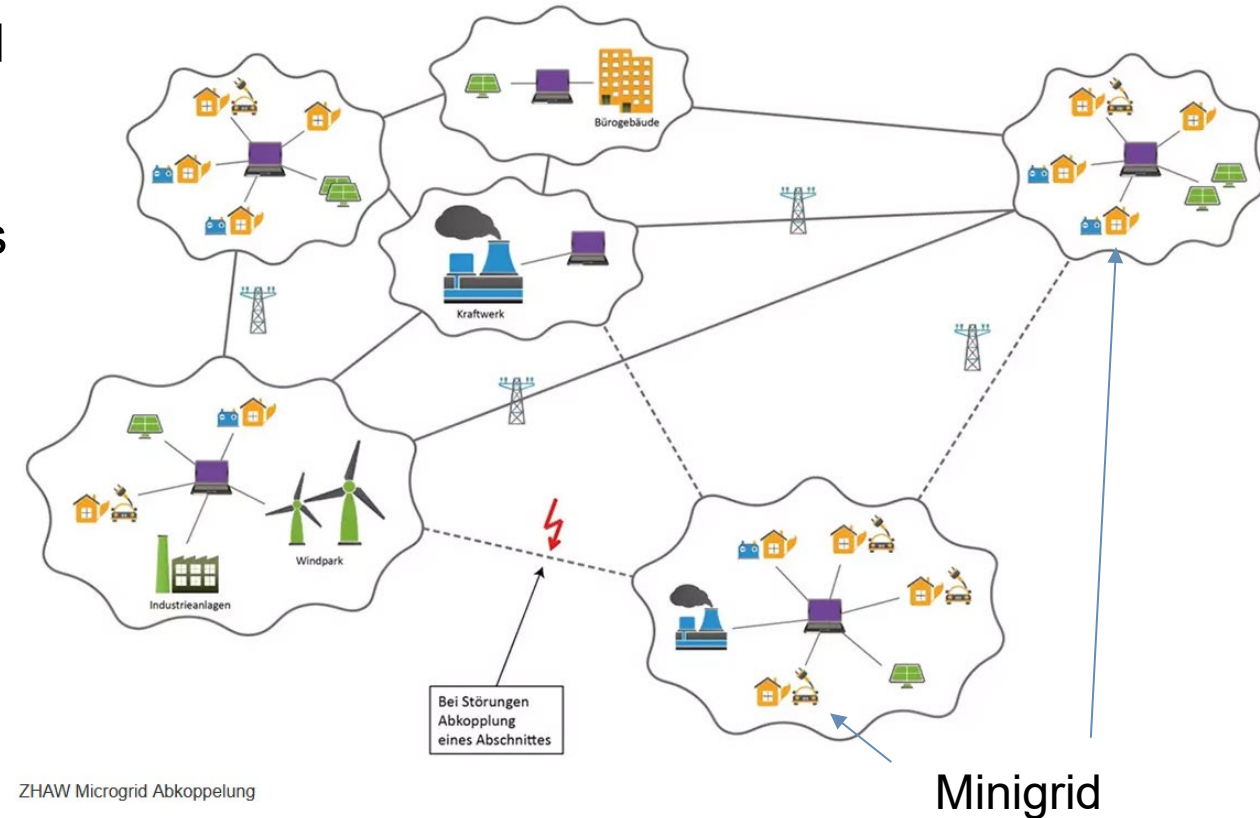

# Energy Communities: A mini-grid can form the technical basis of an energy community



## Different Types of Energy Communities



(a) Prosumer household schematic diagram

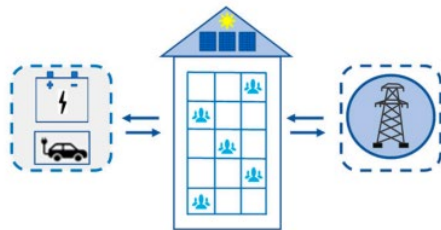

(b) Collective prosumers in one building schematic diagram

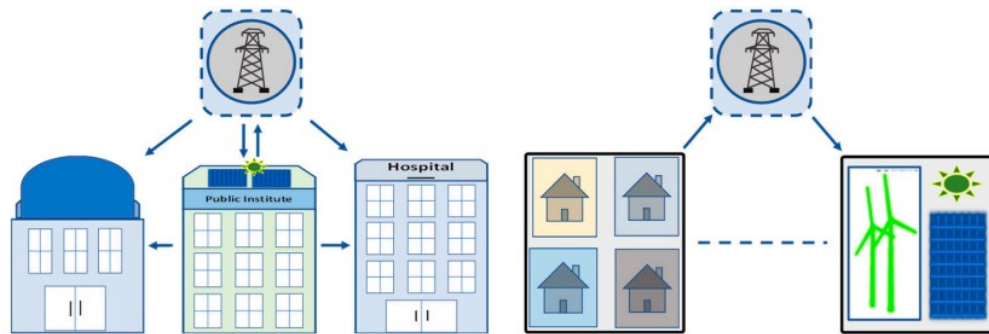

(c) Prosumership for public institutes schematic diagram

(d) Energy community schematic diagram

- Association of stakeholders (citizens, municipalities, companies) for joint energy generation, use, and marketing.
- Goal: Participation in the energy transition and strengthening local value creation.
- Focus on ecological, social, and economic benefits
- Use of renewable energies and often decentralized plants
- Energy exchange takes place via the public grid or local infrastructures
- Promotes energy self-sufficiency, sustainability, and citizen participation

# Renewable Energy Technologies of Mini-Grids or Energy Communities



Mini-grids enable local energy autonomy but can also be flexibly connected to a higher-level grid

This connection mainly serves to:

- Stabilize the mini-grid if local generation and storage are insufficient.
- Feed surplus energy into the grid or purchase electricity when local production is too low.

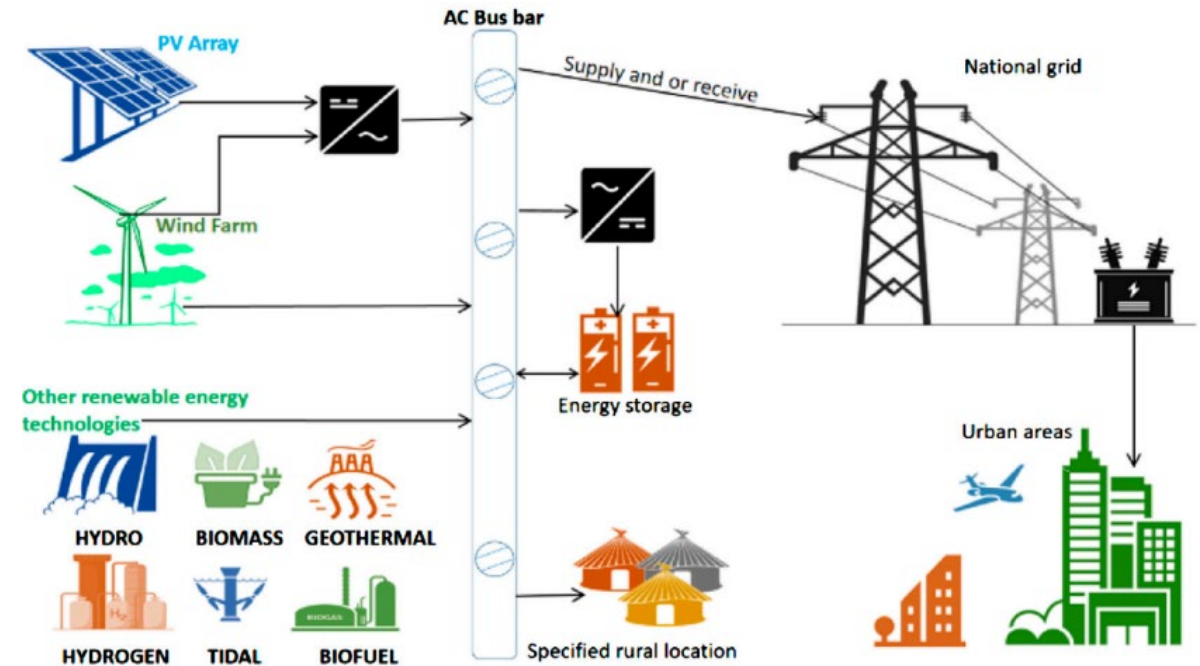

1. Introduction
2. Self-consumption and energy communities
3. Technological requirements and challenges
4. Economic Relevance
5. Experience report from Germany
6. Opportunities and prospects for Cape Verde



# System Requirements of Mini-Grids and Energy Communities



Mini Grids allow embedding devices in the energy control system by making information available

## Basic requirements

- Reliability
- Resilience
- Stability
- Low infrastructure costs

## Today's requirements

- Increasing efficiency
- Enabling energy flexibility
- Adapting to external effects

## Future requirements

- Open interfaces
- Information availability
- Versatile infrastructure



# Types of Mini-Grids: DC with Storage

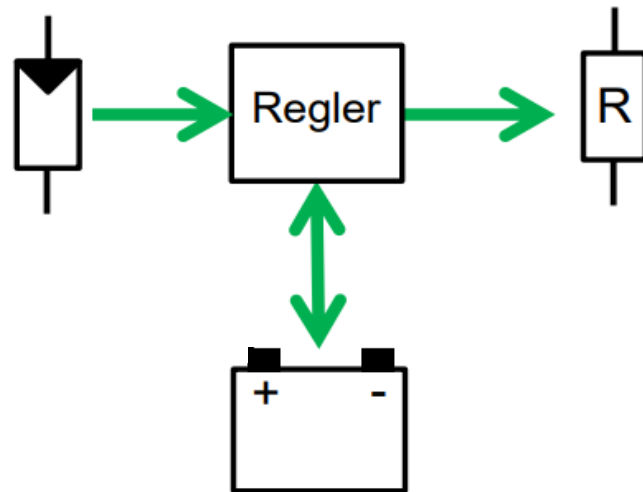

- A storage device is connected between the solar module and the load
- Advantages:
  - Bridging during darkness
  - Load peaks possible
- Disadvantages:
  - Charge management usually required
  - Costs
  - Battery life

# Types of Mini-Grids: Hybrid System

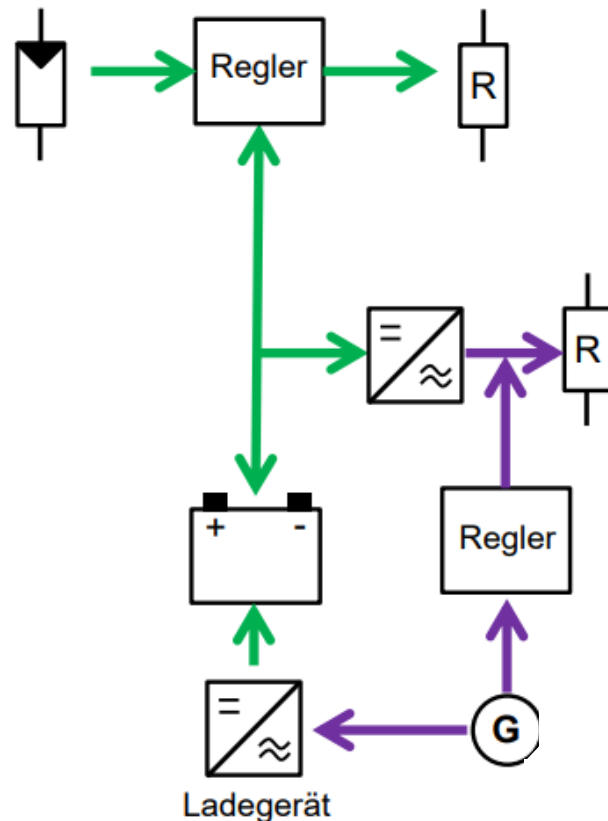

- Support through an additional energy source
  - Gasoline/Diesel generator
  - Windpower
  - Hydropower
  - Grid
- Advantages
  - Power increases
  - Energy increases
  - Higher reliability / safety
  - Battery charging possible
- Disadvantages
  - Costs
  - Synchronization necessary
  - Maintenance-intensive (generator)
  - fuel supply dependence → logistical challenges, cost volatility

# Key Elements of Energy Communities

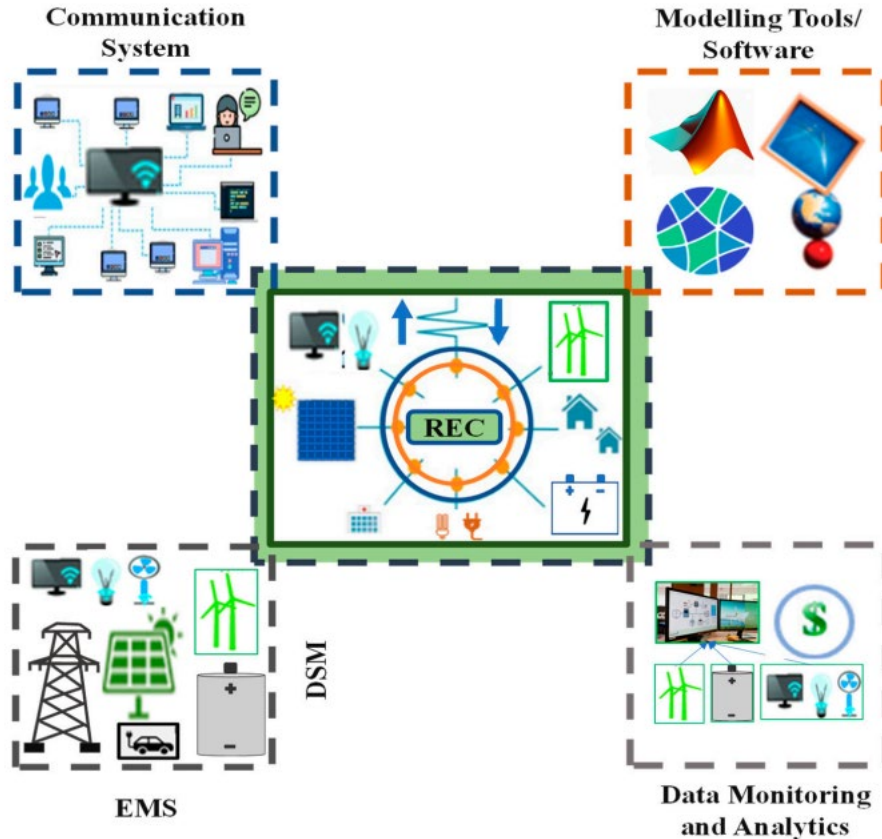

## Requirements:

- Energy Management System
- Demand Side Management
- Data analysis
- Communication

## Challenges:

- Integration of heterogeneous systems
- Lack of architecture standards
- Data security
- Scaling

# Decentral Control System for stable Energy Distribution

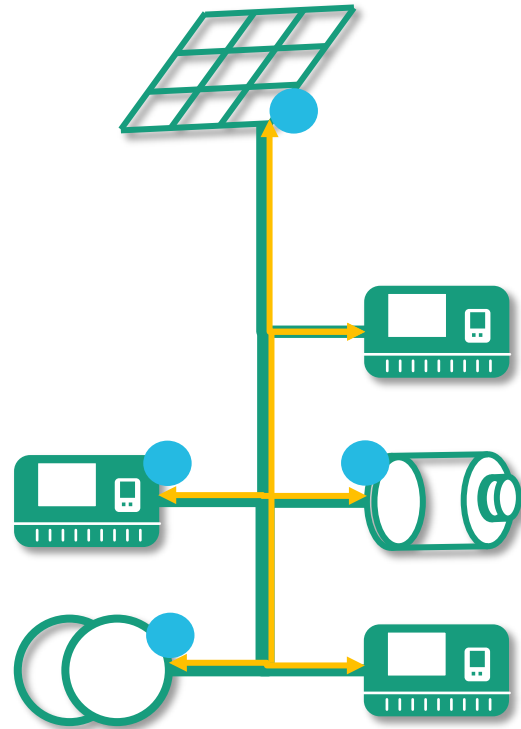

- ↔ Information exchange
- Energy transmission
- Droop controlled

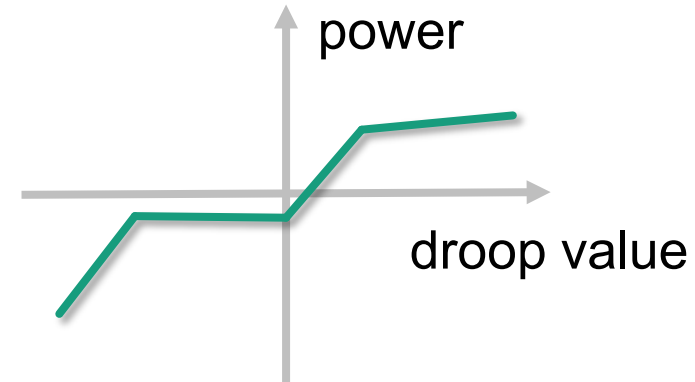

## Operation Principle

- Modulation of energy availability as information on droop value
- Power control distributed in single devices
- Optional integration of any grid devices

# Decentral Control System for stable Energy Distribution

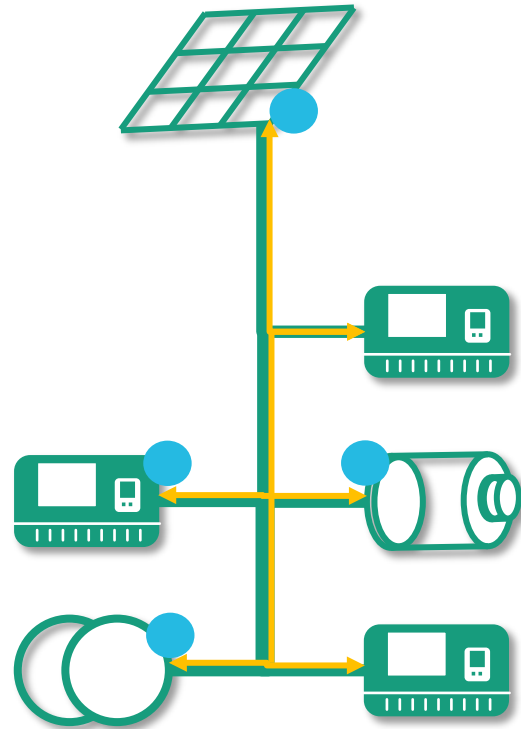

↔ Information exchange

— Energy transmission

● Droop controlled

## Advantages

- No additional infrastructure for data transfer
- Increased reliability by distributed control system
- Modular expandability
- Optional integration of energy flexible loads
- Enabling optimized operation strategies
- Simple customization of control system for state of the art power electronic devices

1. Introduction
2. Self-consumption and energy communities
3. Technological requirements and challenges
4. Economic Relevance
5. Experience report from Germany
6. Opportunities and prospects for Cape Verde



# Economic Challenges



## Economic challenges

- Isolated mini-grids often have low load factors (<25%), especially with demand peaks only in the evening.
- Low revenues make it hard to cover O&M costs or repay investments.
- High tariffs or subsidies are needed; otherwise, systems risk falling into disrepair.
- Limited investor interest due to low profitability.
- Productive daytime uses are essential to increase load and revenue

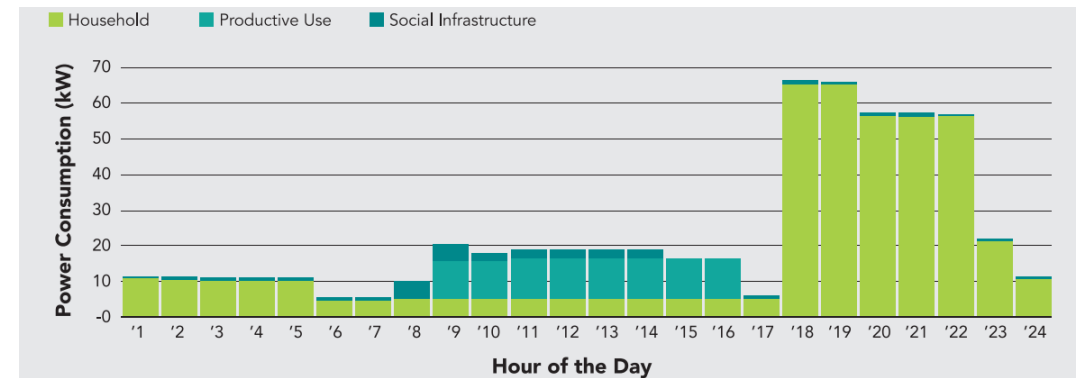

→ Without targeted integration of productive daytime use, storage solutions, and clear regulatory frameworks, the economic viability of many mini-grids in Cape Verde remains limited.

# Economic Evaluation of the Use of Energy Storage Systems

## Use-Cases to optimise energy consumption



Increasing efficiency of energy conversion technologies

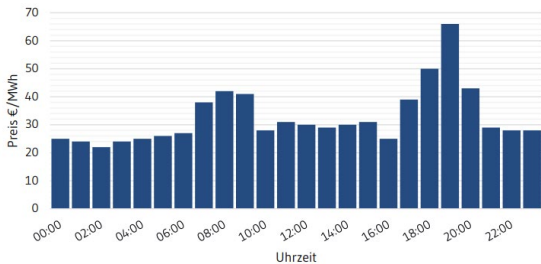
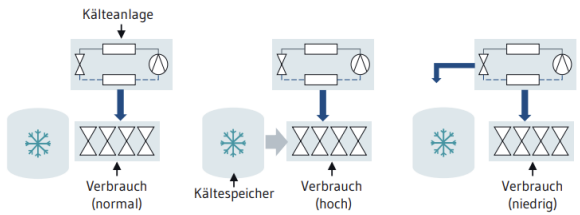

Use of dynamic electricity prices

Peak-Shaving

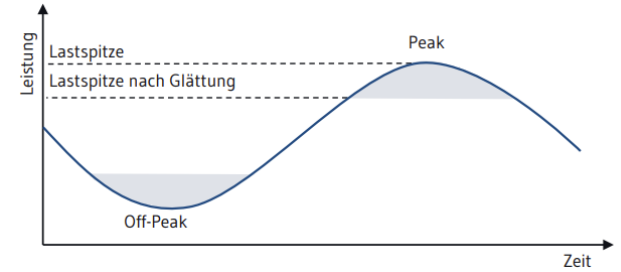

Atypical grid usage

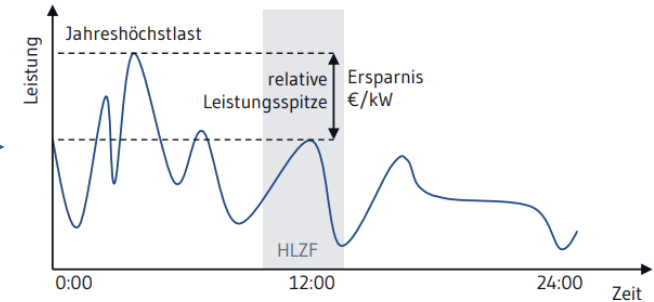

Self-consumption optimization of renewable energy

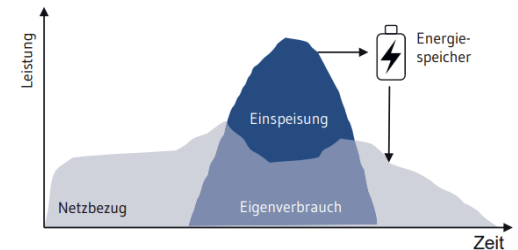

1. Introduction
2. Self-consumption and energy communities
3. Technological requirements and challenges
4. Economic Relevance
5. Experience report from Germany
6. Opportunities and prospects for Cape Verde



# Planning Objects of an industrial DC network



All relevant design objects of the industrial DC network must be taken into account in the planning process:

- Energy supply feed-in
  - MV/LV transformers
  - Active or passive rectifier
  - Filter technology
  - Grounding and network configuration
- DC protection technology
  - Circuit breakers, fuses
  - Pre-charging devices
- Energy storage
  - Storage type (battery storage, supercapacitors, etc.)
  - Localization of storage

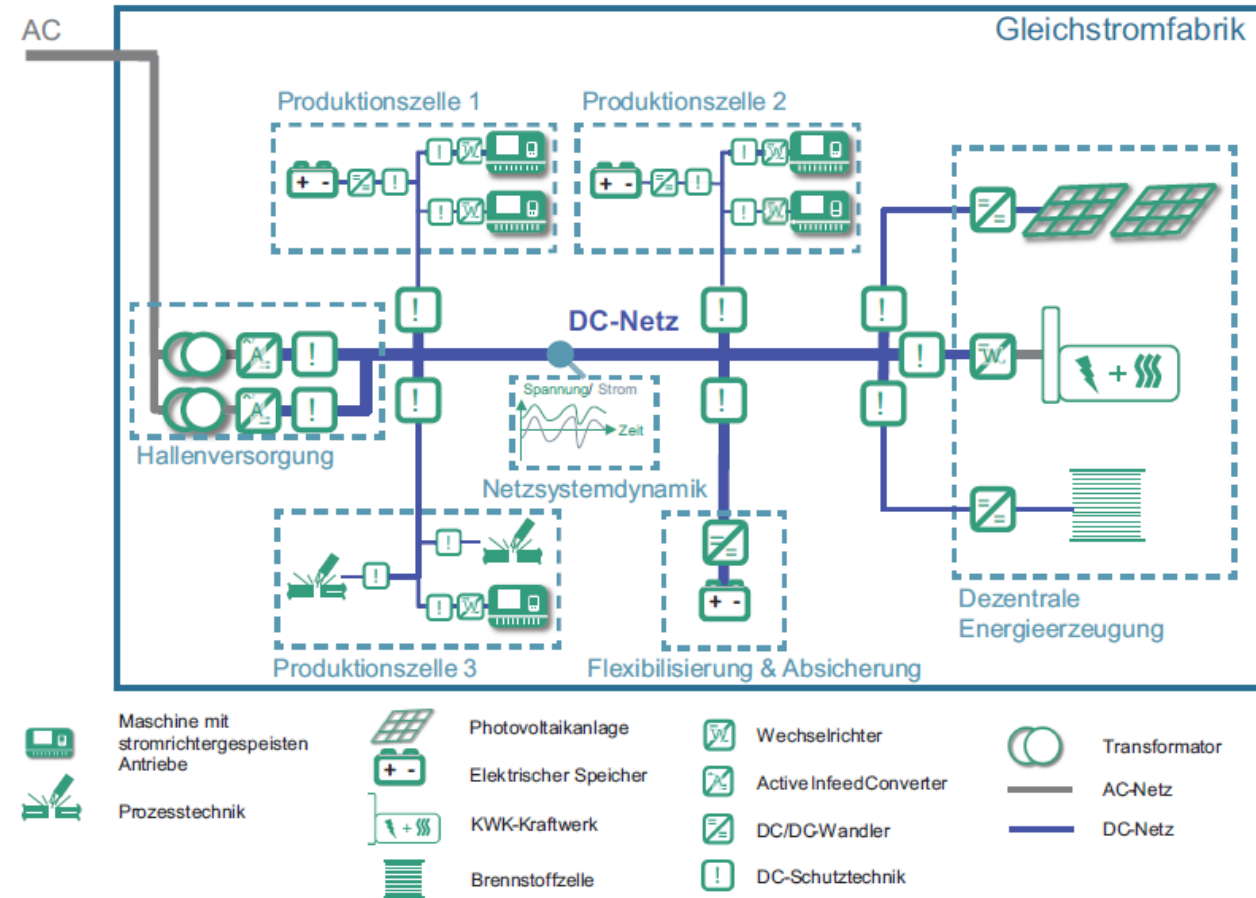

# Planning Objects of an industrial DC network



- Generation facilities
  - PV system, CHP power plant, fuel cell, etc.
- Consumption facilities
  - Power class, energy demand
  - Dynamics of consumers, e.g., robots
- Power converters
  - Connection of consumer facilities, e.g., inverters
  - Connection of generation facilities and storage, e.g., boost converters
- Grid management
  - Control requirements for grid participants for primary control
  - Requirements for grid participants due to the desired secondary and tertiary control

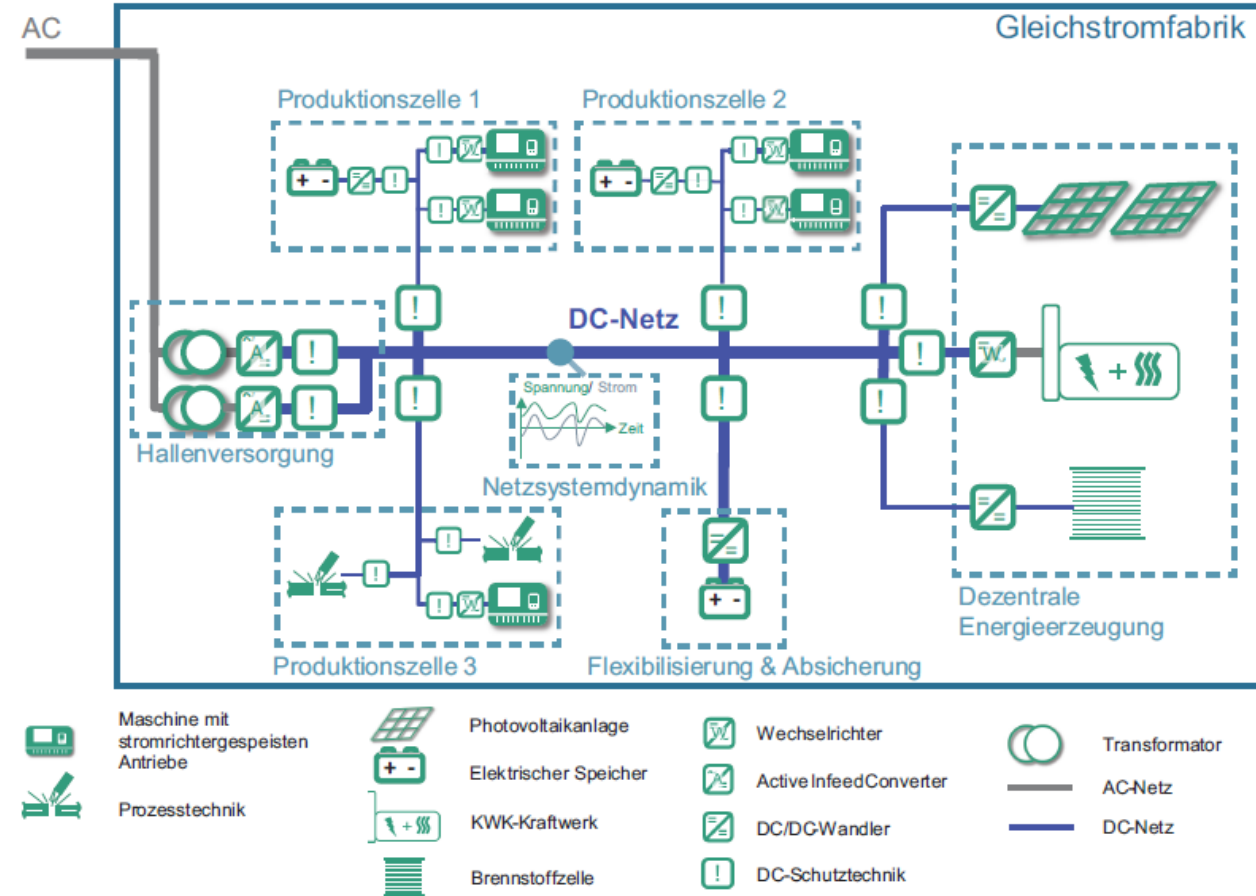

# DC Mini-Grid – a Game Changer in Electrical Supply for Energy Efficiency



## NEXt Factory der Fa. Schaltbau in Velden

Solaranlage mit elektr. Energiespeicher und Einspeisung

NEXt Factory  
Efficient. Smart. Green.



### Energy generation and storage

- Photovoltaic (PV) energy:
  - Annual generation: 1,900 MWh
  - Directly usable: 1,200 MWh per year
- Battery storage: 300 kWh

### Application scenario

- 700V DC grid integrates PV system, battery, logistics area, hall ventilation, lighting, and charging of electric vehicles

### Results

- > 60% reduction in electrical energy losses
- 30% reduction in annual peak load in the overall energy system
- 35% reduction in total energy costs

# DC Technology has already made the Leap into Industrial Applications



## DC in Hall Infrastructure Supply

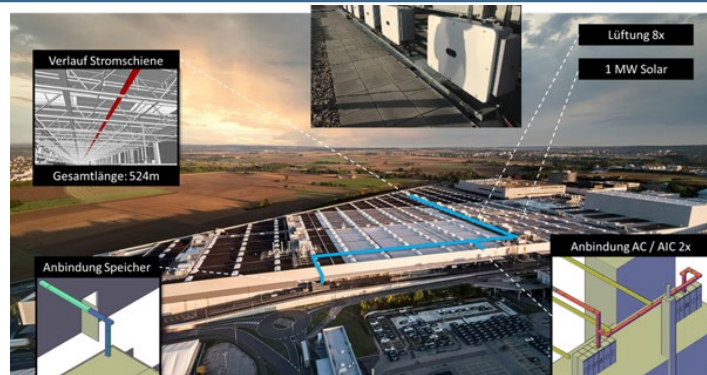

DC-Industrie  
(Mercedes-Benz  
Factory 56)

- High-power DC grid (2 MW)
- Integration of PV, ventilation system, storage, and future lighting
- Goal: Energy flexibility and energy efficiency in a robust and intelligent supply system

## Production Facilities

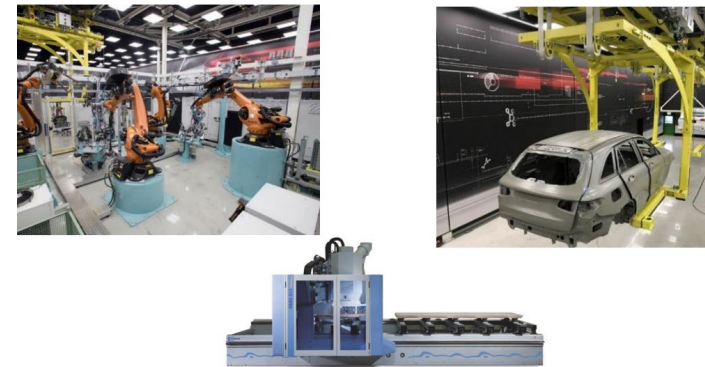

DC-Industrie (BMW,  
Mercedes-Benz,  
KUKA, HOMAG)

- Production facilities up to 15% energy savings
- Reduction in decentralized rectifier power by up to 60-80%
- Goal: Energy efficiency in production facility technology, ensuring energy supply quality

1. Introduction
2. Self-consumption and energy communities
3. Technological requirements and challenges
4. Economic Relevance
5. Experience report from Germany
6. Opportunities and prospects for Cape Verde



# Africa Mini-Grid Landscape: Rise in diesel-solar Hybrid Systems



## Total new minigrid sites by technology type (from 2021 to 2024)

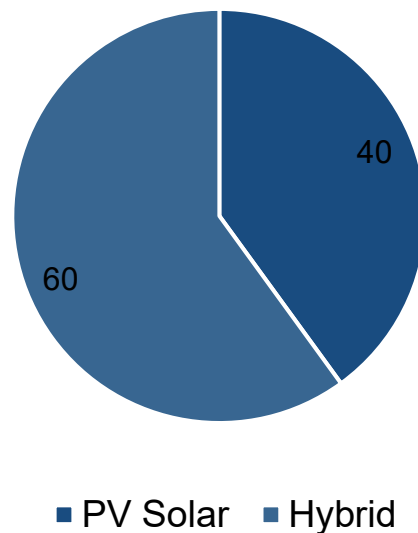

- Hybrid solar PV + diesel dominates, shifting from PV-battery systems
- Enhances service reliability and addresses renewable variability
- Balances low PV costs with moderate storage needs
- Declining battery costs reduce need for oversized systems
- Supports innovation, sustainability, and customer satisfaction

# Transferable Experiences in the field of Mini-Grids and Energy Communities

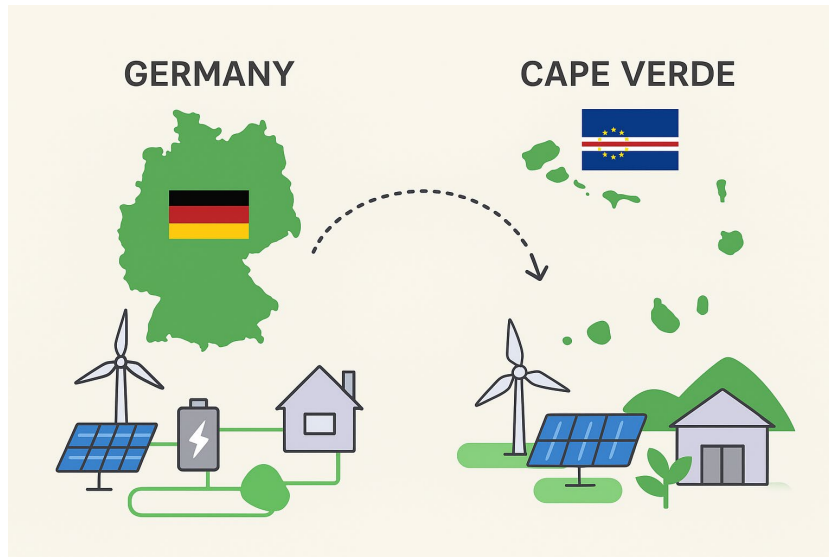

- Hybrid and island grids
- Battery storage and load management
- Power electronics and control
- Integration of renewable sources
- Economic operating models
- Monitoring, maintenance, and digitalization



Federal Ministry  
for Economic Affairs  
and Energy



MITTELSTAND  
**GLOBAL**  
ENERGY SOLUTIONS  
MADE IN GERMANY

# Thank you!

**Yvonne Eboumbou Ebongue**  
Research Associate



+49 711 970 – 3514

[yvonne.eboumbou.ebongue@ipa.fraunhofer.de](mailto:yvonne.eboumbou.ebongue@ipa.fraunhofer.de)

[yvonne.eboumbou-ebongue@eep.uni-stuttgart.de](mailto:yvonne.eboumbou-ebongue@eep.uni-stuttgart.de)



Deutsch-Portugiesische  
Industrie- und Handelskammer  
Câmara de Comércio e Indústria  
Luso-Alemã



implemented by